



Single Axis Servo Driven Robot

ST1-700-1400DT



Refer carefully to this manual before operation.

■ Coding Principle

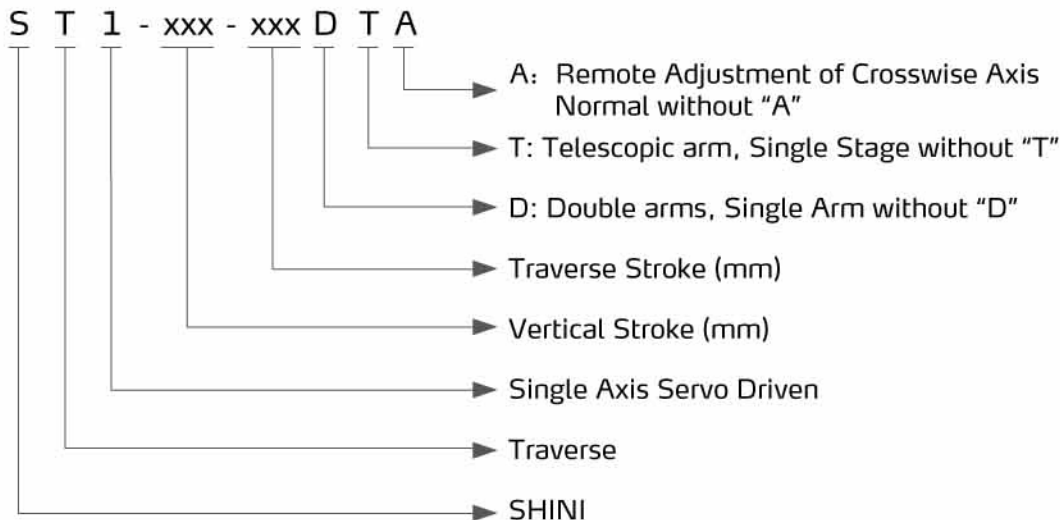

■ Features

● Appearance

Designed with elegant appearance; Aluminium profiles are largely used to provide compact and streamlined appearance.

● Precision

Traverse movement is driven by heavy duty servo motor with cooperation of precise linear guide rails and high power V belts; Fast, silent, and precise. Wrist mechanism employs pneumatic driven rack and pinion system, which accomplishes smooth, stable and precise flipping motion. Vertical arm(s) with telescopic design efficiently minimizes the cycle time and height of the robot.

● Safety

High efficient shock absorbers allow fast and precise pneumatic driven motion. Drop proof locking mechanism prevents accidents due to malfunction of pneumatic source. Position limit sensors and blocks effectively prevent mechanical and electrical malfunctions. Control board is designed to CE EMC test with short circuit and noise proof functions.



ST1-1300-2000DT



ST1-700-1400T

ST1 Series

- Convenience

Vertical and crosswise displacements can be adjusted simply by changing the position limit blocks in easy directions. Control board fixtures are designed with flyer structure which provides benefit to maintenance. Cable drag chains help with cable management and ease for maintenance.

- Standardization

All pneumatic accessories, electric accessories, and communication protocols meet the global standards. Interface between injection molding machine and robot is designed to EUROMAP 12, EUROMAP 67 and SPI.

- Intelligence

User friendly control system and graphical user interface automatically monitor and display error messages with addition of memorizing last 50 errors messages. Flexible and dialogic programming scheme offer 20 standard programs and 80 customized programs.

- User Friendly

Plug and use industrial connectors achieve simple installation and un-installation. Servo driven axis provides the possibility of multi points for positioning products and sprues. Multi languages displays and spared communication connections with surrounds machines offer more flexibilities to global customers.



Control Panel

■ Application

The ST1 series robot is designed for rapid and precise removal of sprue and products from injection molding machine, and place them at desired locations. Standard and telescopic arm(s) are selectable according to the application of 2-plate mold, 3-plate mold or hot runner system. Stacking function provides 2 stop points in X and Y axis, multiple stop points in Z axis. Suitable for injection molding machine under 850T clamp force.

■ Outline Drawings

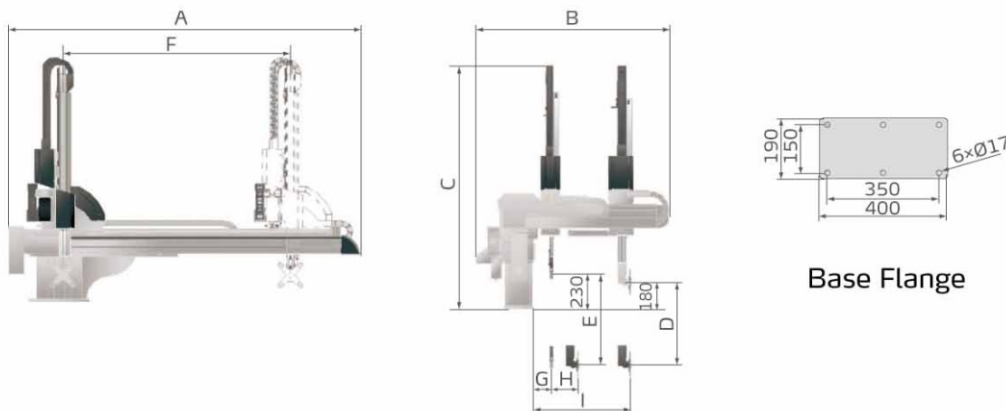

Single Axis Servo

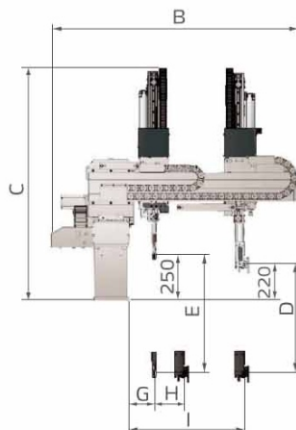
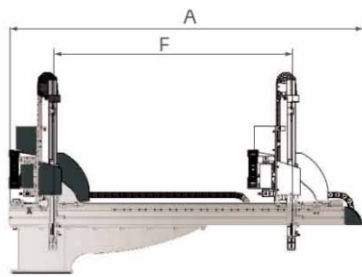

Base Flange

Single Axis Servo Telescopic

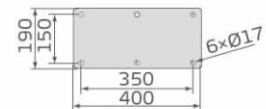
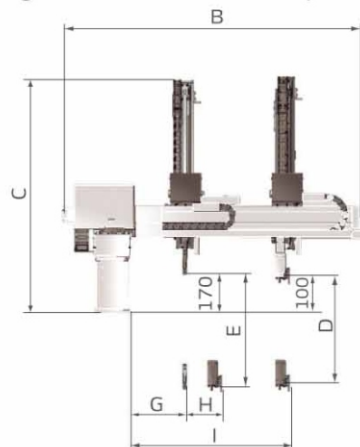
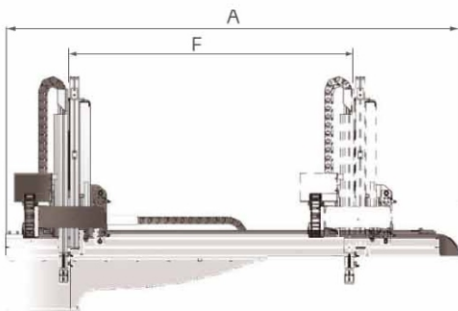

Base Flange

Single Axis Servo Medium Telescopic

■ Specifications

Model		ST1-700-1400	ST1-700-1400D
IMM (ton)		100 ~ 200	100 ~ 200
Traverse Stroke (mm)		1400	1400
Crosswise Stroke (mm)	Main arm	150	150
	Sub arm	/	100
Vertical Stroke (mm)	Main arm	700	700
	Sub arm	/	750
Max Load (with tool) (kg)		3	3
Min Pick-out Time (sec)		2.7	2.7
Min Cycle Time (sec)		8	8
Air Pressure (bar)		4 ~ 6	4 ~ 6
Max Air Consumption (Nl/cycle) *		11	17
Weight (kg)		240	260
Dimensions (mm)	A	2150	2150
	B	1300	1300
	C	1650	1650
	D (max)	700	700
	E (max)	/	750
	F (max)	1400	1400
	G (min)	/	120
	H (min)	/	180
	I (max)	700	700

ST1 Series

Model(Single stage)		ST1-900-1600	ST1-900-1600D	ST1-1100-1800	ST1-1100-1800D
IMM (ton)		200 ~ 300	200 ~ 300	300 ~ 450	300 ~ 450
Traverse Stroke (mm)		1600	1600	1800	1800
Crosswise Stroke (mm)	Main arm	250	250	300	300
	Sub arm	/	100	/	150
Vertical Stroke (mm)	Main arm	900	900	1100	1100
	Sub arm	/	950	/	1150
Max Load (with tool) (kg)		5	5	5	5
Min Pick-out Time (sec)		3	3	3.3	3.3
Min Cycle Time (sec)		9	9	10	10
Air Pressure (bar)		4 ~ 6	4 ~ 6	4 ~ 6	4 ~ 6
Max Air Consumption (NI/cycle) *		15	22	17	26
Weight (kg)		250	270	280	290
Dimensions (mm)	A	2350	2350	2550	2550
	B	1400	1400	1600	1600
	C	1850	1850	2050	2050
	D (max)	900	900	1100	1100
	E (max)	/	950	/	1150
	F (max)	1600	1600	1800	1800
	G (min)	/	120	/	120
	H (min)	/	180	/	180
	I (max)	800	800	900	900

- Notes: 1). "M" stands for middle mold detector. (Suitable for three-plate mold.)
 "EM12" stands for EUROMAP 12 communication interface.
 "EM67" stands for EUROMAP 67 communication interface.
 "N" stands for non-operation side,operation side without "N"
 2). Power supply requirement: 1Φ, 200~240V, 50/60Hz.
 3). " * " Max air consumption for vacuum device 60NI/min.

We reserve the right to change specifications without prior notice.

Model (Telescopic)		ST1-700-1400T	ST1-700-1400DT	ST1-900-1600T	ST1-900-1600DT
IMM (ton)		100 ~ 200	100 ~ 200	200 ~ 300	200 ~ 300
Traverse Stroke (mm)		1400	1400	1600	1600
Crosswise Stroke (mm)	Main arm	150	150	250	250
	Sub arm	/	100	/	150
Vertical Stroke (mm)	Main arm	700	700	900	900
	Sub arm	/	750	/	950
Max Load (with tool) (kg)		3	3	3	3
Min Pick-out Time (sec)		2.0	2.3	2.0	2.3
Min Cycle Time (sec)		6.8	6.8	7.2	7.2
Air Pressure (bar)		4 ~ 6	4 ~ 6	4 ~ 6	4 ~ 6
Max Air Consumption (NI/cycle) *		10	16	12	19
Weight (kg)		290	310	300	320
Dimensions (mm)	A	2150	2150	2350	2350
	B	1300	1300	1400	1400
	C	1250	1250	1350	1350
	D(max)	700	700	900	900
	E(max)	/	750	/	950
	F(max)	1400	1400	1600	1600
	G(min)	/	120	/	120
	H(min)	/	180	/	180
	I(max)	730	730	850	850

- Notes: 1). "M" stands for middle mold detector. (Suitable for three-plate mold.)
 "EM12" stands for EUROMAP 12 communication interface.
 "EM67" stands for EUROMAP 67 communication interface.
 "N" stands for non-operation side,operation side without "N"
 2). Power supply requirement: 1Φ, 200~240V, 50/60Hz.
 3). " * " Max air consumption for vacuum device 60NI/min.

We reserve the right to change specifications without prior notice.



Model (Medium Telescopic)		ST1-1100-1800T	ST1-1100-1800DT	ST1-1300-2000T	ST1-1300-2000DT
IMM (ton)		300 ~ 450	300 ~ 450	450 ~ 650	450 ~ 650
Traverse Stroke (mm)		1800	1800	2000	2000
Crosswise Stroke (mm)	Main arm	400	400	400	400
	Sub arm	/	200	/	200
Vertical Stroke (mm)	Main arm	1100	1100	1300	1300
	Sub arm	/	1150	/	1350
Max Load (with tool) (kg)		5	5	5	5
Min Pick-out Time (sec)		2.5	2.5	2.8	2.8
Min Cycle Time (sec)		7.6	7.6	8	8
Air Pressure (bar)		4 ~ 6	4 ~ 6	4 ~ 6	4 ~ 6
Max Air Consumption (NI/cycle) *		24	37	26	41
Weight (kg)		420	450	440	470
Dimensions (mm)	A	2570	2570	2770	2770
	B	1750	1750	1750	1750
	C	1390	1390	1490	1490
	D (max)	1100	1100	1300	1300
	E (max)	/	1150	/	1350
	F (max)	1800	1800	2000	2000
	G (min)	/	120	/	120
	H (min)	/	180	/	180
	I (max)	1150	1150	1150	1150

Model (Medium Telescopic)		ST1-1500-2200T	ST1-1500-2200DT
IMM (ton)		650 ~ 850	650 ~ 850
Traverse Stroke (mm)		2200	2200
Crosswise Stroke (mm)	Main arm	400	400
	Sub arm	/	200
Vertical Stroke (mm)	Main arm	1500	1500
	Sub arm	/	1550
Max Load (with tool) (kg)		6	6
Min Pick-out Time (sec)		3	3
Min Cycle Time (sec)		8.5	8.5
Air Pressure (bar)		4 ~ 6	4 ~ 6
Max Air Consumption (NI/cycle) *		29	45
Weight (kg)		460	490
Dimensions (mm)	A	2970	2970
	B	1750	1750
	C	1590	1590
	D (max)	1500	1500
	E (max)	/	1550
	F (max)	2200	2200
	G (min)	/	120
	H (min)	/	180
	I (max)	1150	1150

- Notes: 1). "M" stands for middle mold detector. (Suitable for three-plate mold.)
 "EM12" stands for EUROMAP 12 communication interface.
 "EM67" stands for EUROMAP 67 communication interface.
 "N" stands for non-operation side, operation side without "N"
 2). Power supply requirement: 1Φ, 200~240V, 50/60Hz.
 3). " * " Max air consumption for vacuum device 60NI/min.

We reserve the right to change specifications without prior notice.

Shini Group

Addr: No. 23, Minhe St., Shulin Dist.,
New Taipei, Taiwan

Tel: +886 2 2680 9119

Fax: +886 2 2680 9229

Email: shini@shini.com

Factories:

- Taiwan
- Dongguan
- Pinghu
- Ningbo
- Chongqing
- Mumbai

2015-10-15-04 Copyrights Reserved.

www.shini.com